



GUIDEMASTER®

TACTILE INDICATORS



PRODUCT DATA SHEET

Published August 2023

GMSSS12

*Guidemaster Hazard / Warning Tactile Indicator
—Black Powder Coated Solid Stainless Steel*

GMSSS12 Guidemaster Tactile Ground Surface Indicator – A Heavy Duty black powder coated 316 marine grade stainless steel warning tactile indicator, recommended for indoors and outdoors, commercial carparks, footpaths, shopping centres, hospitals, schools – any public spaces requiring accessibility treatment.



SPECIFICATIONS

Masterspec Code	Interior: 6615FG / Exterior: 8281FG
Warranties	Installation warranty: 1 year Product warranty: 2 years
Luminance Test	Provides colour contrast. Discrete Tactiles must be 45% to that of the surround substrate surface area.
Code Compliance	NZTA RTS14 —Land Transport New Zealand – Guidelines for facilities for the blind and vision impaired. AS/NZS 1428.4.2009 —Design for access and mobility, Part 4 NZS4121:2001 —Design for access and mobility—building and associated facilities All slip resistance tests are done in accordance with AS/NZS4586:2004 Land Transport’s Pedestrian Planning and Design Guide The Royal N.Z. Foundation for the Blind Design Guide Recommendations/ Specifications

Base Material	Black Powder Coated Solid 316 Marine Grade Stainless Steel
Dimensions	Outer: 35mm Top: 25mm
Features & Application	Provides warning to the blind and visually impaired
Installation Methods	Drill and Adhesive Fix or Drill and Friction Fit in accordance to New Zealand Standards
Sustainability	Declare Label Certified LBC Compliant—Red List Approved
Slip Resistance Rating	P5 WET and DRY - SRV Value of 80

- 8 Cooper Street, Havelock North 4130
PO Box 8740, Havelock North 4130
- Unit 2, 24 Inlet Road, Takanini
Auckland 2112
- 09 320 1338 or Toll Free 0800 687 004

ARCHITECTURAL PRODUCTS



Page 1





GUIDEMASTER®

TACTILE INDICATORS



PRODUCT TECHNICAL DRAWING

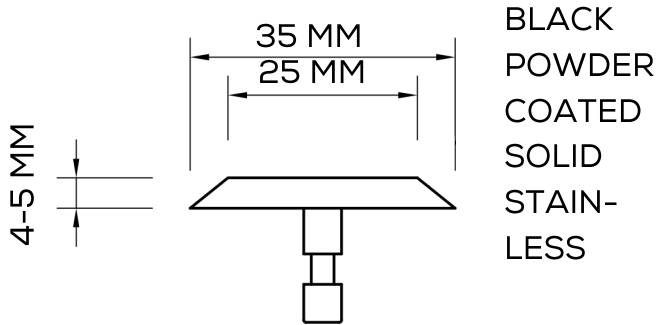

SIDE VIEW

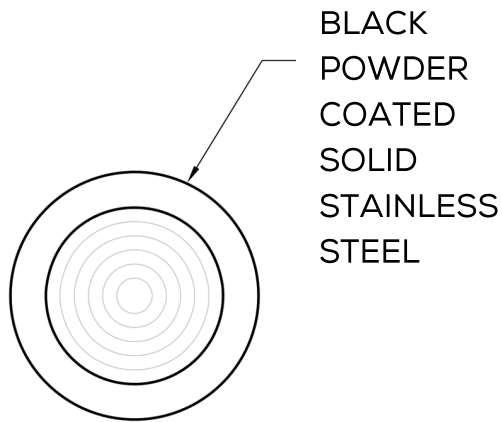

TOP VIEW

PREVIOUS PROJECTS



8 Cooper Street, Havelock North 4130
PO Box 8740, Havelock North 4130

Unit 2, 24 Inlet Road, Takanini
Auckland 2112

09 320 1338 or Toll Free 0800 687 004

ARCHITECTURAL PRODUCTS

TREADMASTER®
ENTRANCE MATTING

GUIDEMASTER®
TACTILE INDICATORS

STEPMASTER®
STAIR NOSINGS

STRIDEMASTER®
WALKWAY INSERTS

HALTMASTER®
TRAFFIC MANAGEMENT

Page 2

